

50016

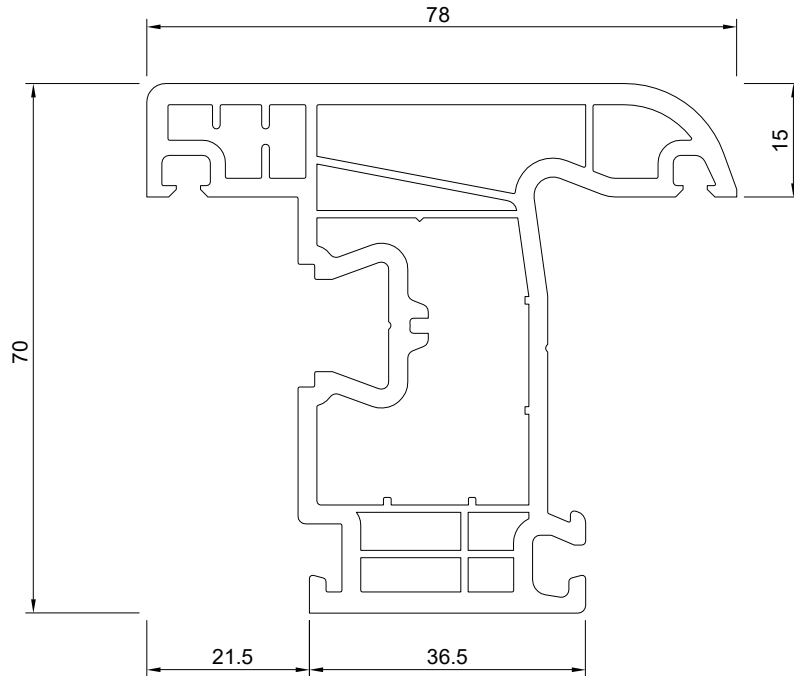

50001

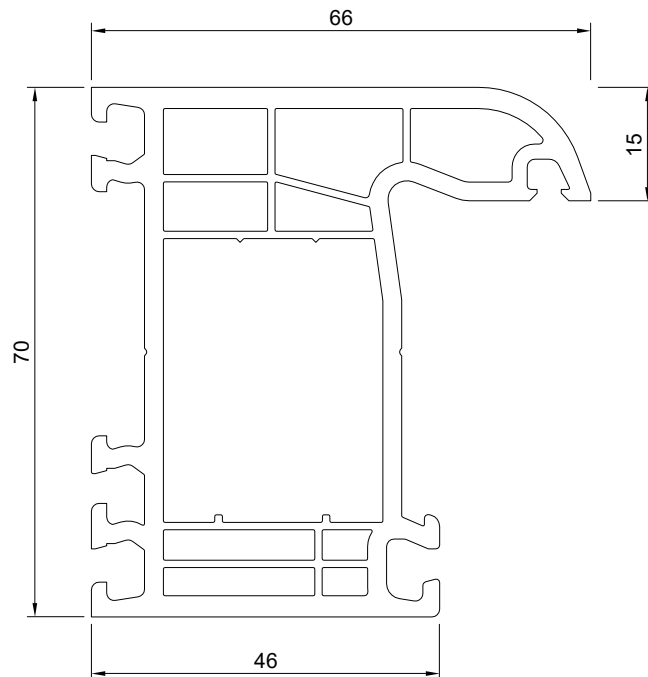

50003

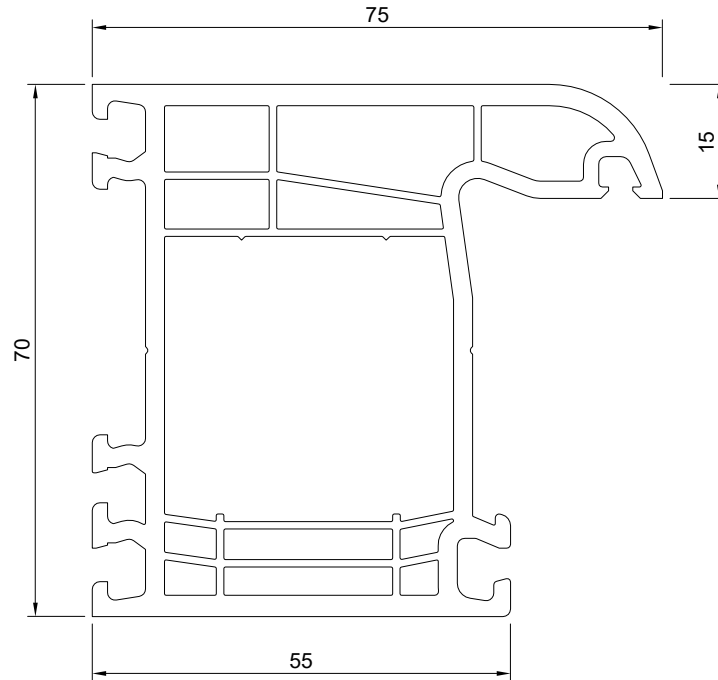

50004

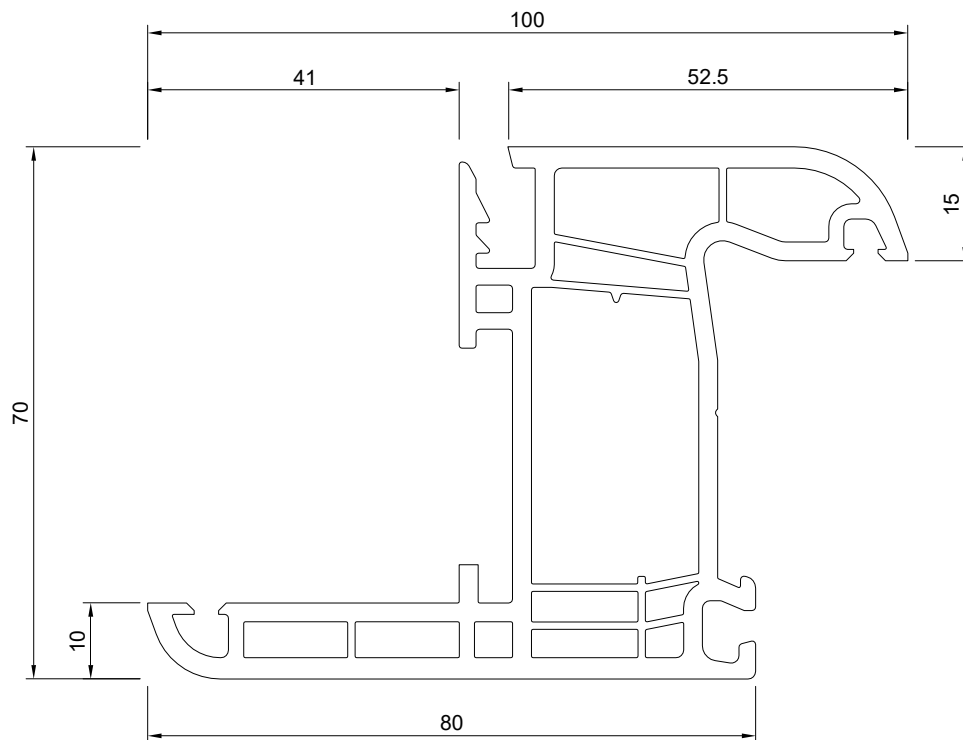

50005

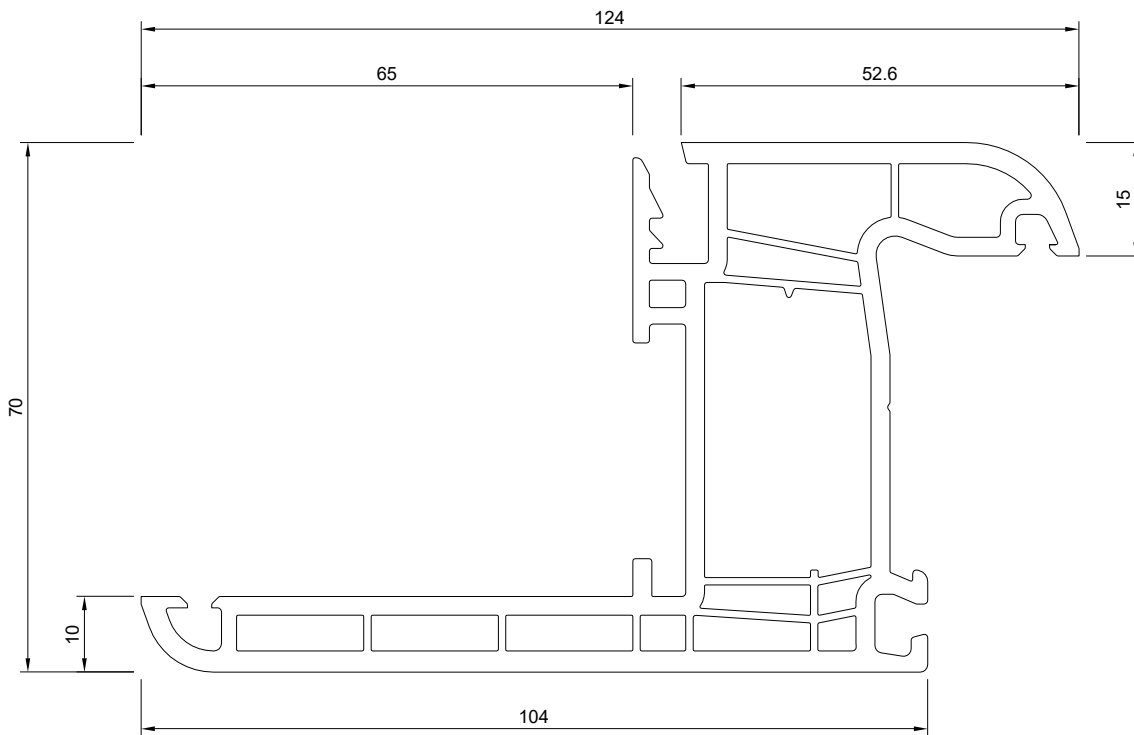

50009

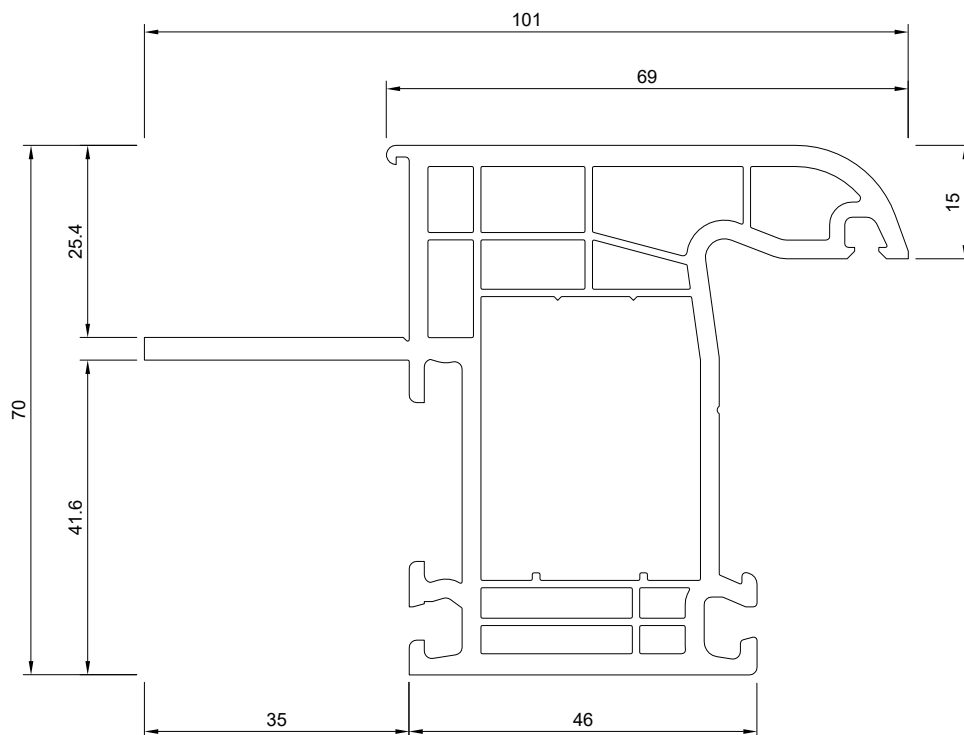

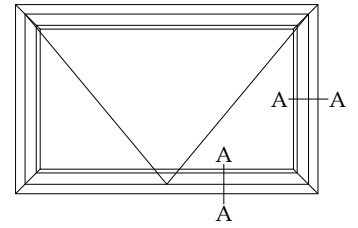
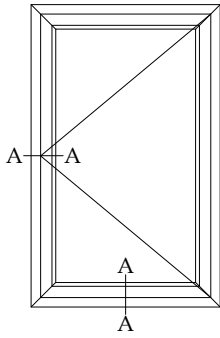

**50924 + 50016 + 50001**

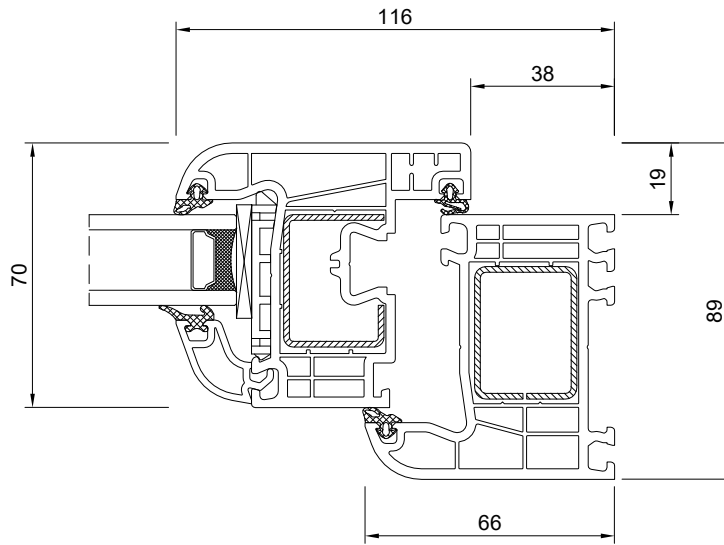

A A

**50924 + 50016 + 50003**

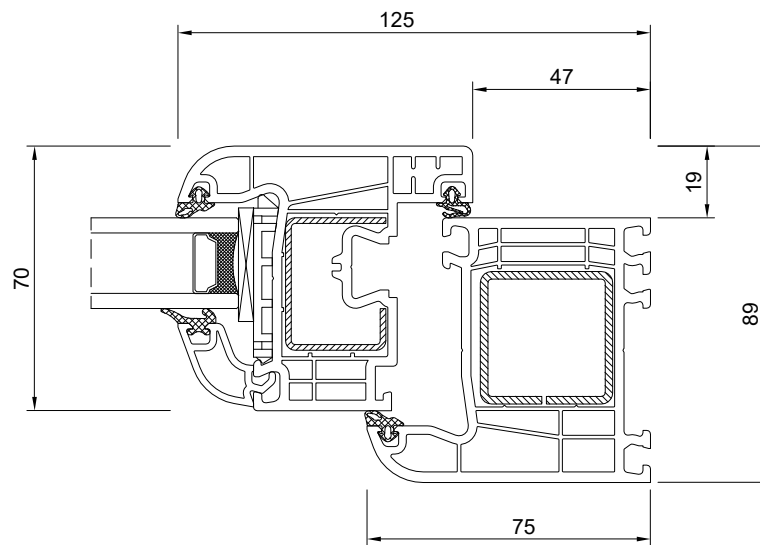

A A

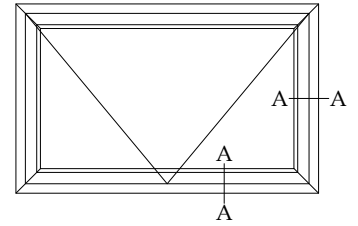
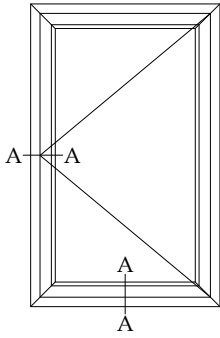

**50924 + 50016 + 50004**

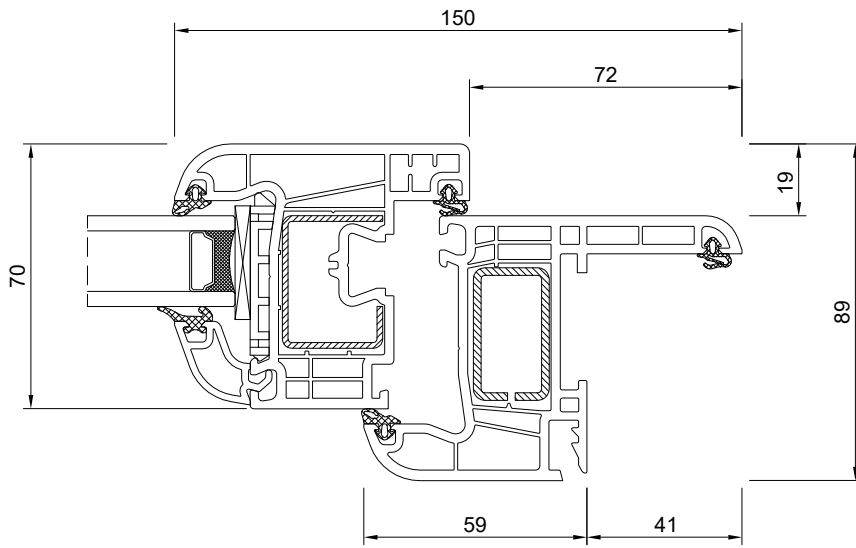

A A

**50924 + 50016 + 50005**

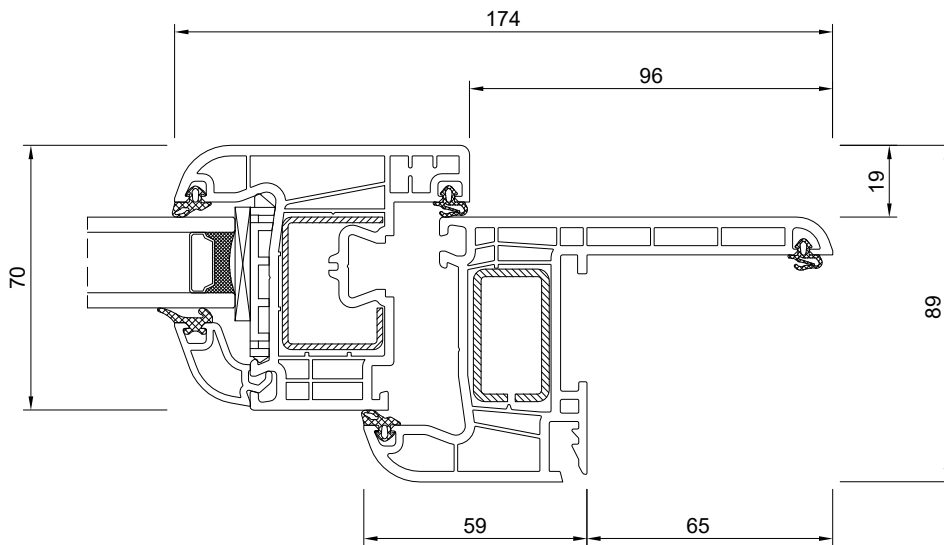

A A

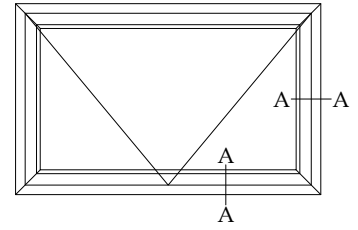
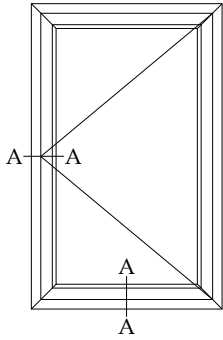

50924 + 50016 + 50009

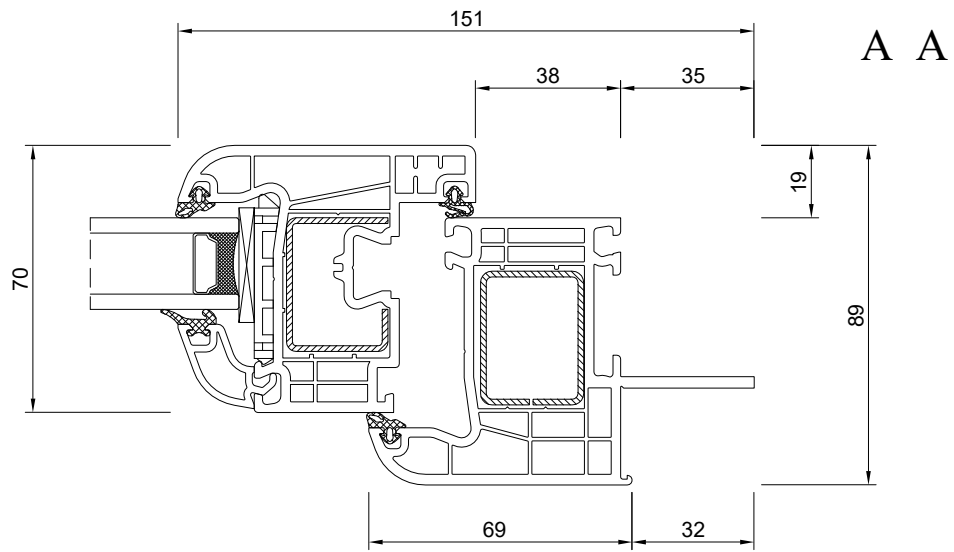

50924 + 50016 + 50021

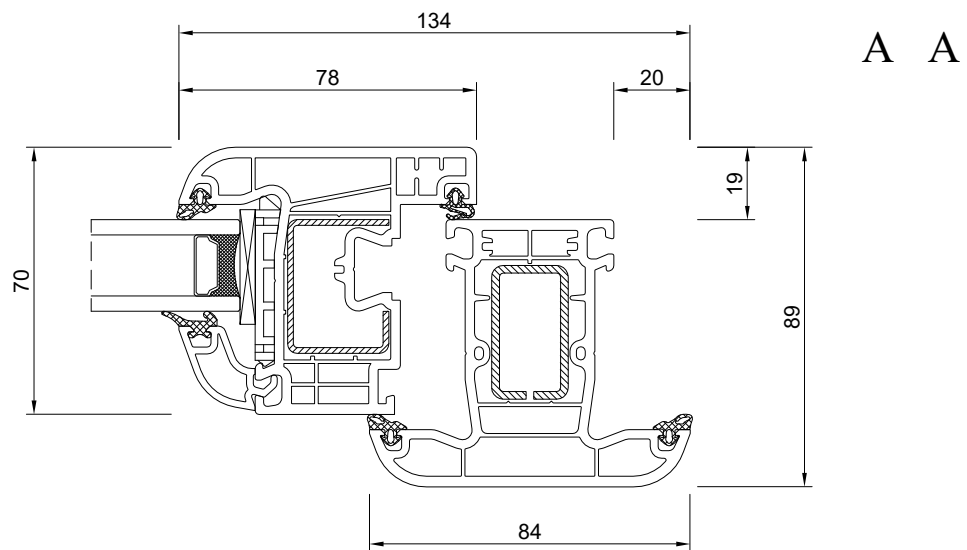

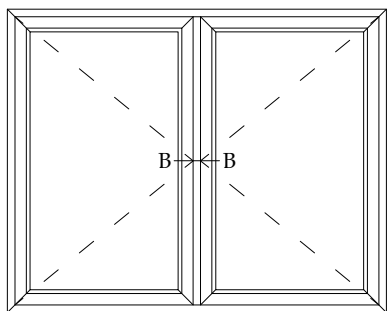

50924 + 50016 + 50021 + 50016 + 50924

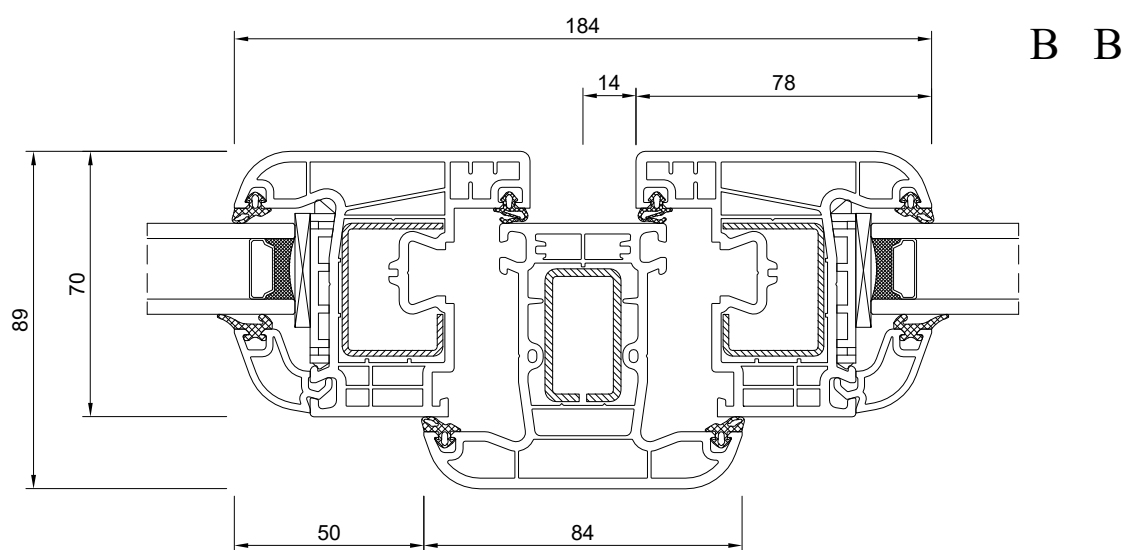

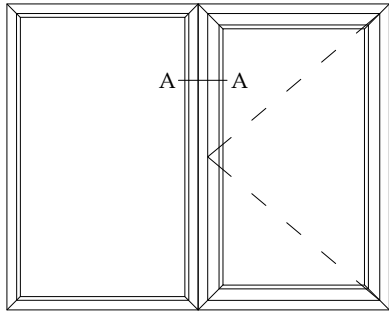

50924 + 50001 + 50110 + 50001 + 50016 + 50924

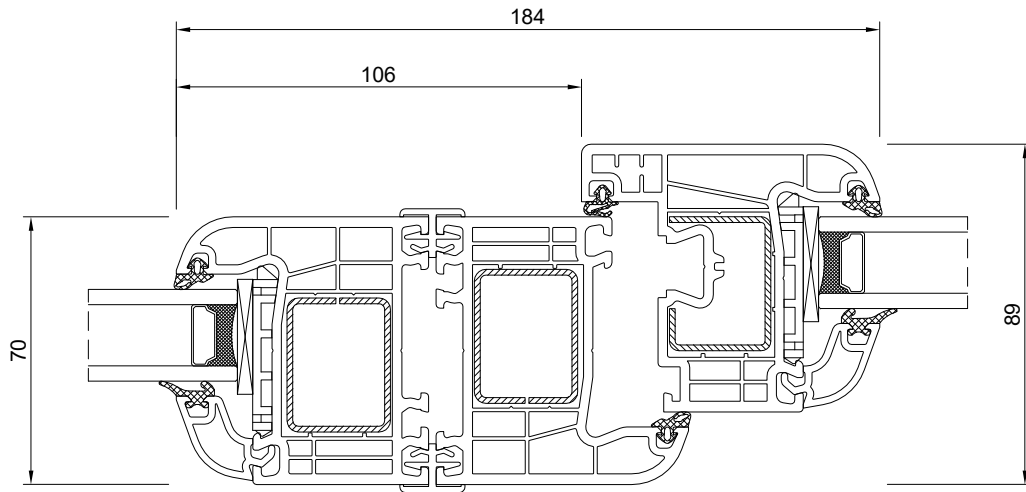

50924 + 50001 + 50111 + 50001 + 50016 + 50924

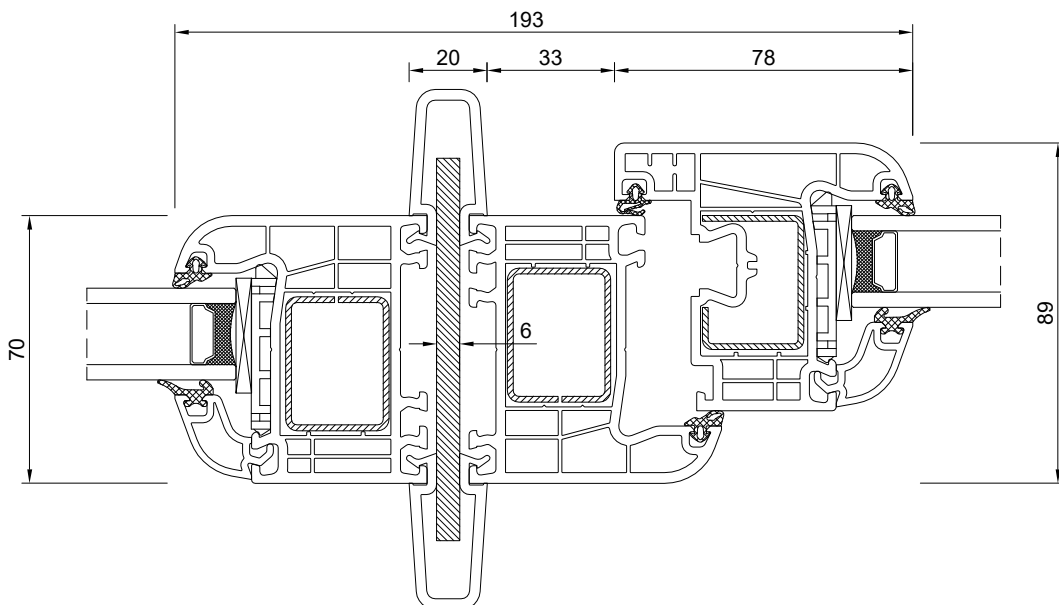



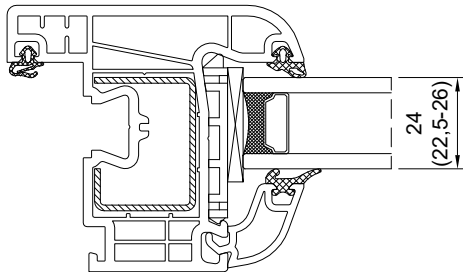

Listwa 50924

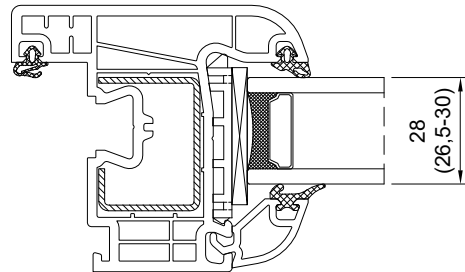

Listwa 50928

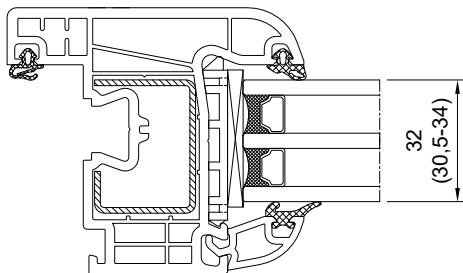

Listwa 50932

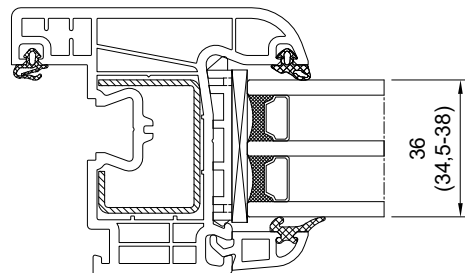

Listwa 50936

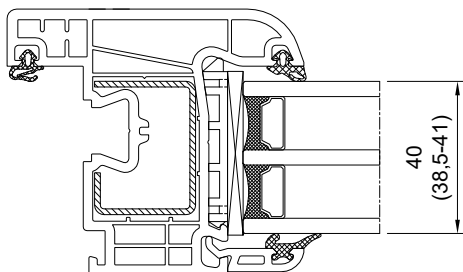

Listwa 50940

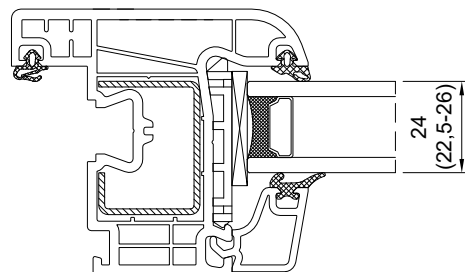

Listwa 50924A

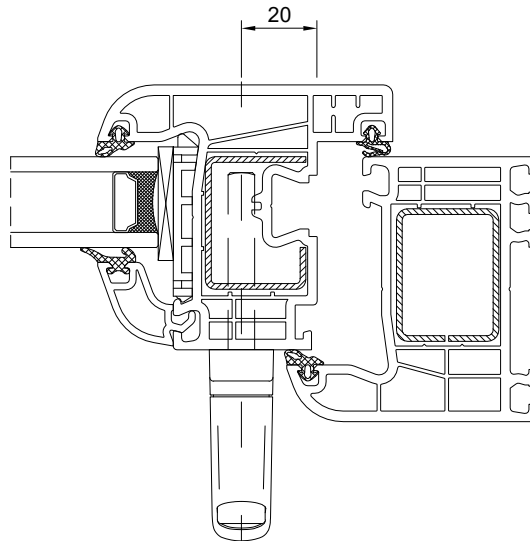
**Iglo PREMIER - DM 20**

Öffnungswinkel der Ausstellbeschläge je nach Größe und Gewicht:  
Bänder Typ 8230 - 60 Grad – Breite 350 – 550mm, max. 22kg  
Bänder Typ 8240 - 50 Grad – Breite 450 – 1000, max. 45kg  
Bänder Typ 8260 - 38 Grad – Breite 650 – 1500mm, max. 60kg  
Näheres bei der Produktion anfragen.